

INDUSTRIAL THERMOMETER

BBG FILLED SYSTEM



SPECIAL FEATURES

- STAINLESS STEEL CASE & MEASURING SYSTEM
- EVERY ANGLE MOUNTING AVAILABLE
- DRY OR LIQUID FILLED
- INERT GAS FILLED EXPANSION SYSTEM.
- STANDARD FOLLOWED EN 13190.

APPLICATIONS

CHEMICALS / REFINERY / FERTILIZER / PETROCHEMICALS /
PHARMACEUTICAL / POWER / CEMENT / SUGAR / FOOD &
BEVERAGES / PULP & PAPER & ALLIED PROCESS INDUSTRIES.



SPECIFICATIONS

STANDARD VERSION : 100MM, 120mm, 150mm, 200mm, 250mm

Accuracy	: Class 1 as per EN 13190
Ambient Temperature	: -25°C to 65°C
Operating Pressure	: 15kg/cm ² (without thermowell)
Over Range Limit	: 30% of full scale range or 650°C whichever is min.
Stem Diameter	: 6mm / 8mm / 9,5mm / 10mm / 12mm

Case	: AISI 304SS, 316SS
Ring	: AISI 304SS, Bayonet Lock
Movement	: AISI 304SS
Stem	: AISI 316SS
Connection	: AISI 316SS
Joints	: Tig argon arc welding

Protection	: IP 65
Dial	: Aluminium, black graduation on white background
Pointer	: Aluminium, black Coloured Micrometer Zero adjustable
Window	: Sheet Glass
Gasket	: Neoprene

TYPE 3

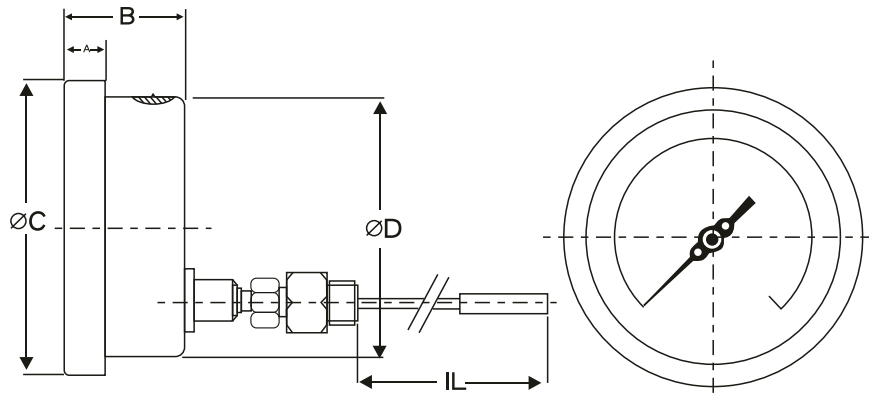

NS	A	B	$\varnothing C$	$\varnothing D$	IL
100	12.5	48	110	100	*
125	11	49	131	119	*
150	15	48	161	149	*
200	15	49	210.5	210.5	*
250	15	50.5	263	249	*

(* ASPER CUSTOMER REQUIREMENT.)

TYPE 4

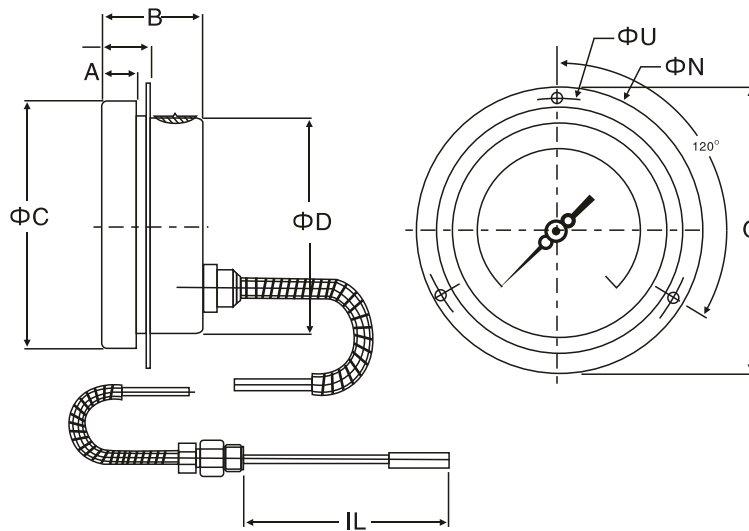

NS	A	B	ΦC	ΦD	S	IL	ΦU	ΦN	ΦI
100	12.5	48	110	100	6	*	118	134	6
125	11	49	131	119	4	*	138	152	6
150	15	48	161	149	5.5	*	168	186	6
200	15	49	210.5	210.5	1.5	*	230	245	8
250	15	50.5	263	249	1.5	*	276	290	8

(* ASPER CUSTOMER REQUIREMENT.)

TYPE 3

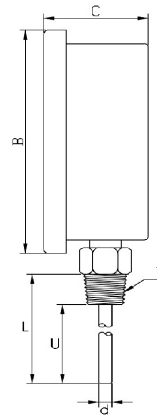
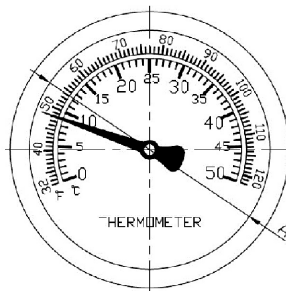

單位: mm

NS	A	B	ØC	Ød	IL
100	103	118	50	6.35	100
125	11	49	131	119	*
150	15	48	161	149	*
200	15	49	210.5	210.5	*
250	15	50.5	263	249	*

(* ASPER CUSTOMER REQUIREMENT.)

TYPE 4

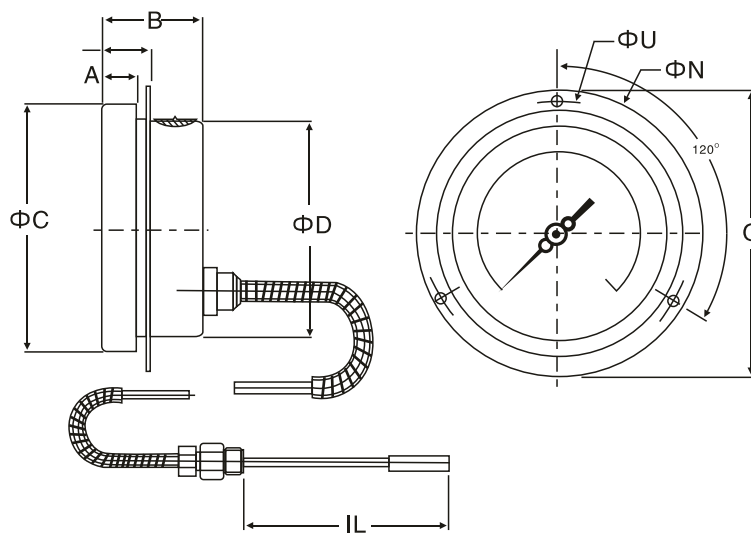

NS	A	B	ΦC	ΦD	S	IL	ΦU	ΦN	ΦI
100	12.5	48	110	100	6	*	118	134	6
125	11	49	131	119	4	*	138	152	6
150	15	48	161	149	5.5	*	168	186	6
200	15	49	210.5	210.5	1.5	*	230	245	8
250	15	50.5	263	249	1.5	*	276	290	8

(* ASPER CUSTOMER REQUIREMENT.)

TYPE 8

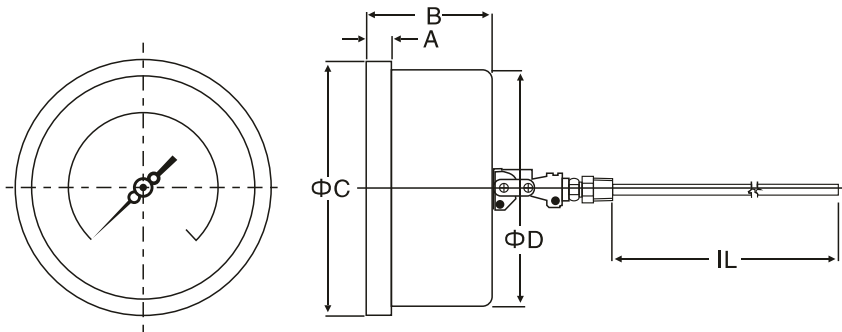

NS	A	B	ΦC	ΦD	IL
100	12.5	48	110	100	*
125	11	49	131	119	*
150	15	48	161	149	*
200	15	49	210.5	210.5	*
250	15	50.5	263	249	*

(* AS PER CUSTOMER REQUIREMENT.)

TYPE 9

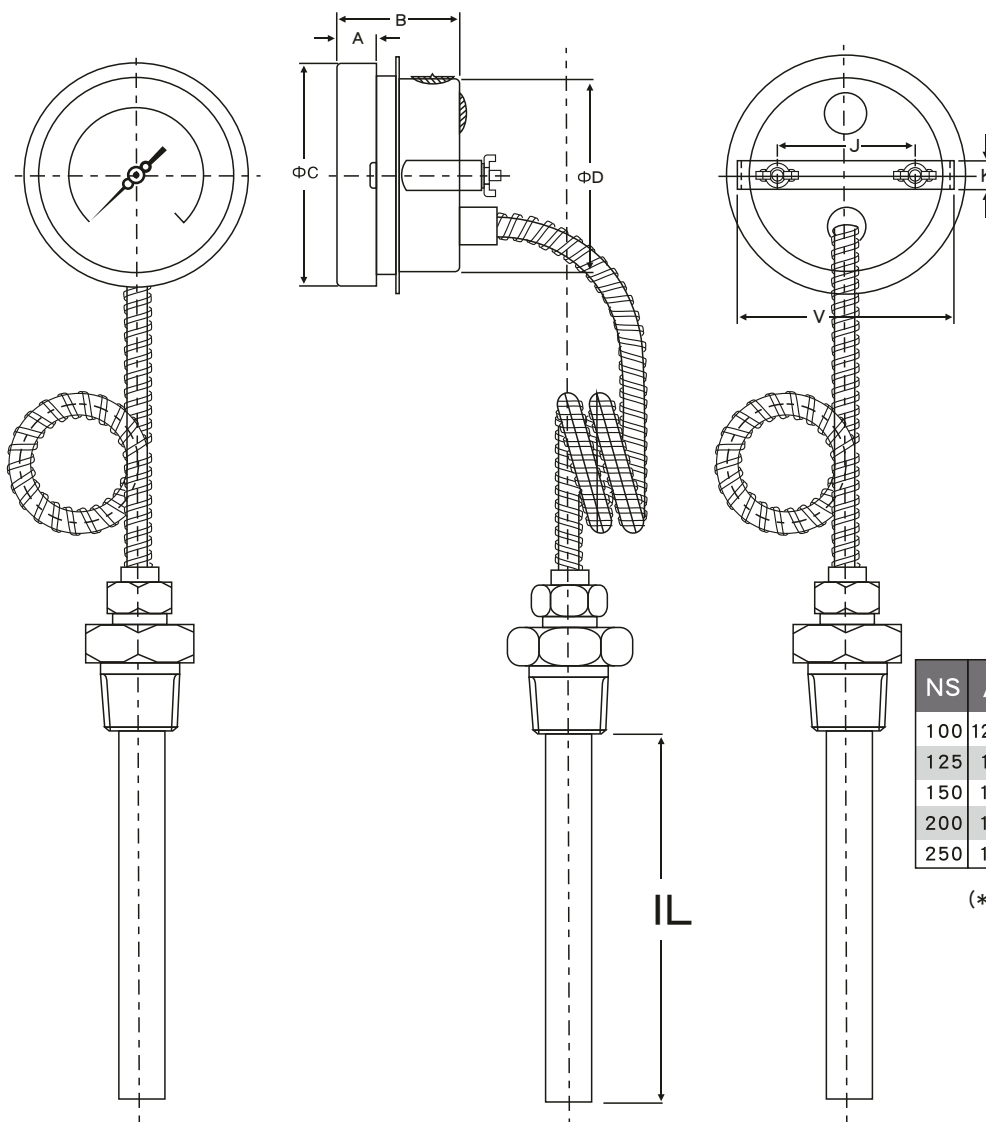

NS	A	B	ΦC	ΦD	IL	J	K	V
100	12.5	48	110	100	*	66.5	16	106
125	11	49	131	119	*	80	16	129.5
150	15	48	161	149	*	103.5	16	158
200	15	49	210.5	210.5	*	165	16	208
250	15	50.5	263	249	*	215	16	260

(* AS PER CUSTOMER REQUIREMENT.)

Notes: • Drawings are not to scale. • All Dimensions are in mm. • NS = Nominal Size

RANGE TABLE

Note : MIX offers National / International Scales like °C, °F & Dual Scale in °C & °F & Scales as per the requirement can be provided on request.

Following are the example tables for °C

STANDARD RANGES

POSITIVE RANGE SINGLE SCALE IN °C			
RANGE	RANGE	RANGE	RANGE
0/50	0/100	0/200	0/500
0/60	0/120	0/300	0/600
0/80	0/150	0/400	0/650
COMPOUND RANGE SINGLE SCALE IN °C			
RANGE	RANGE	RANGE	RANGE
-80/70	-20/60	-20/180	-30/120
-50/50	-20/80	-30/70	-30/170
-80/40	-40/40	-20/40	-20/100
-40/60	-30/50	-20/80	

NOTE: Other compound ranges are available on request. Please consult factory

ACCESSORIES †

EA	Anti Vibration spring	Thermowell	See Data Sheet EI
----	-----------------------	------------	-------------------

† Refer Datasheet for complete specifications

OPTIONS

- C12 AISI 316 SS CASE & BEZEL
- C1 FIVE POINT CALIBRATION CERTIFICATE
- C5 DAMPENING LIQUID SILICON OIL (NOT WITH ELECTRIC CONTACT)*
- C4 DAMPENING LIQUID GLYCERINE (NOT WITH ELECTRIC CONTACT)
- C3 CUSTOM DESIGNED DIAL
- C16 SHATTERPROOF GLASS
- C19 TOUGHENED GLASS
- C36 MAXIMUM READING POINTER (EXCEPT NOMINAL SIZE 125mm/200mm/250mm & OPTION ELECTRIC CONTACT & DAMPENING LIQUID)
- C35 DIAL TAG MARKING
- C9 SS TAG PLATE
- C37 ANTI VIBRATION SPRING (Not available in mounting type 8 and capillary option)
 - * GASKET & PLUG OF VITON / NBR

C12

ELECTRIC CONTACTS

(WITH IP PROTECTION UP TO IP55, NOT AVAILABLE FOR NS 125mm, 200mm & 250mm)

A) MAGNETIC SNAP ACTION TYPE (230 V AC, 1 Amp.) B) INDUCTIVE TYPE (220 VAC, 0.4 Amp.)
(48 VDC, 0.5 Amp.)

- | | |
|---|---|
| D1 Single; NORMALLY CLOSED | D10 Single; NORMALLY OPEN |
| D2 Double; NORMALLY CLOSED+ NORMALLY OPEN | D11 Single; NORMALLY CLOSED |
| D3 Single; NORMALLY OPEN | D12 Double; NORMALLY CLOSED + NORMALLY OPEN |
| D4 Double; NORMALLY OPEN+ NORMALLY CLOSED | D13 Double; NORMALLY OPEN |
| D5 Double; NORMALLY CLOSED | D14 Double; NORMALLY CLOSED |
| D6 Double; NORMALLY OPEN | D15 Double; NORMALLY OPEN + NORMALLY CLOSED |
| D7 BOOSTER FOR CURRENT UPTO 5Amp. | |
| D8 SPDT | |
| D9 DPDT | |

HOW TO ORDER

BASIC MODEL

CODE	D	E	F	G	H
NOMINAL SIZE (MM)	100	125	150	200	250

TYPE OF MOUNTING

- A4 WALL/ SURFACE/ PROJECTION MOUNTING
WITH BOTTOM ENTRY
- A1 DIRECT BOTTOM ENTRY
- A5 DIRECT LOWER BACK ENTRY
- A6 FLUSH PANEL BACK ENTRY WITH FRONT FLANGE
- A11 EVERY ANGLE BACK ENTRY (W/O CAPILLARY)
- A3 BACK ENTRY WITH MOUNTING BRACKET

GAUGE CONNECTION

- | | |
|-------------------------|---------------------------|
| B20 3/8" BSP(M) | B12 3/8" NPT (M) |
| B9 1/2" BSP(M) STANDARD | B13 1/2" NPT (M) STANDARD |
| B15 1/2" BSPT(M) | B19 M 20 X 1.5 (M) |
| B14 3/8" BSPT(M) | B28 3/4" BSP (M) |

Note: Connections like PT/PF/Flaired /UNF/G/R etc. can be provided on request.
Non standard connections can be provided through adaptors.

STEM DIAMETER

- | | | |
|-----------|----------|---------|
| F1 6.35mm | F5 9.5mm | F4 12mm |
| F3 8mm | F2 10mm | |

TOTAL STEM LENGTH (BELOWCASE)

PLEASE SPECIFY IN mm (INCLUDING IMMERSION & EXTENSION LENGTH)

RANGE

REFER TABLES

TYPE

- G1 WITHOUT CAPILLARY
- G2 WITH CAPILLARY

CAPILLARY

- H1 AISI304 SS H2 AISI316 SS

CAPILLARY COVERED WITH ARMOUR

- I1 AISI304 SS I2 AISI316 SS I3 PVC

CAPILLARY LENGTH(Max up to 25Mtrs.)

IN METERS (e.g. 1.5 = 1.5 METERS 2.0 = 2 METERS)

OPTIONS

REFER OPTIONS TABLE ON PREVIOUS PAGE

FOR NON STANDARD PRODUCTS/OPTIONAL ITEMS, PLEASE CONTACT FACTORY FOR DELIVERY AND MINIMUM QUANTITY OF ORDER.

Ordering Example:

BBG-F-A4-B9-F1-100-100°C-G1-H1-I1-3Mtr.

Notes: • Due to continuous improvement, the specification may vary from time to time.

BBG

F

A4

B9

F1

100

100°C

G1

H1

I1

3 Mtr.